











Laser Triangulation Displacement Sensors





-  **Laser line averages across shiny metallic or structured surfaces**
-  **Four models with measuring ranges from 2mm to 50mm**
-  **Sensor head and separate controller**
-  **Measurement rate up to 10kHz**
-  **RTSC Real Time Surface Compensation**
-  **Analogue and digital output**
-  **Adjustable filter functions (firmware)**
-  **Calibration certificate included**
-  **Configuration via software www.micro-epsilon.com/download**

The optoNCDT 2200LL series uses a small laser line, instead of a spot, to provide accurate measurement against shiny metallic surfaces. The use of the laser line allows the sensor to perform an average across the line. This makes it possible to measure rough surfaces with greater accuracy than before. The sensor can also be used for measuring directly reflecting surfaces without the need to angle the sensor.

MR	SMR	α	φ	ε	A	B
2	24	35.0°	40.0°	44.8°	25.8	16.8
10	30	34.3°	35.2°	35.6°	28.7	20.5
20	40	28.8°	27.5°	26.7°	30.1	22
50	45	26.5°	23.0°	18.3°	31.5	22.5

optoNCDT 2200LL (2/10/20/50mm)

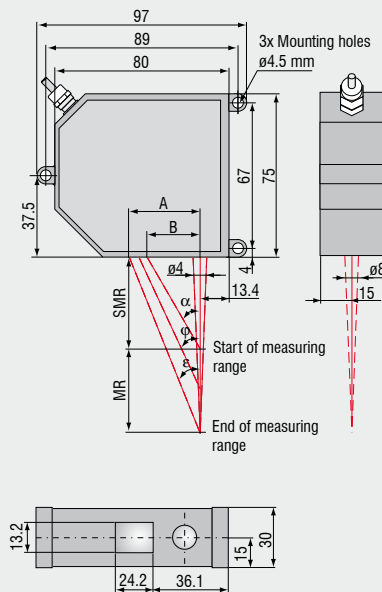

Controller

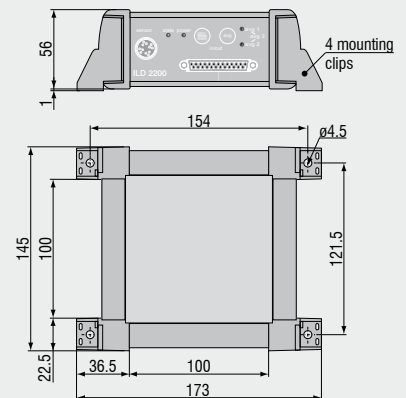

(Dimensions in mm, not to scale. All CAD files are available online.)

Model		ILD 2200-2LL	ILD 2200-10LL	ILD 2200-20LL	ILD 2200-50LL
Measuring range		2mm	10mm	20mm	50mm
Start of measuring range		24mm	30mm	40mm	45mm
Midrange		25mm	35mm	50mm	70mm
End of measuring range		26mm	40mm	60mm	95mm
Linearity		1 μ m $\leq 0.05\%$ FSO	3 μ m	6 μ m $\leq 0.03\%$ FSO	15 μ m
Resolution ^{1) 2)} (at 10kHz without averaging)		0.03 μ m	0.15 μ m	0.3 μ m	0.8 μ m
			0.0015% FSO		
Measuring rate		10kHz			
Permissible ambient light		30.000lx			
Spot diameter	SMR	85 x 240 μ m	120 x 405 μ m	185 x 485 μ m	350 x 320 μ m
	MMR	24 x 280 μ m	35 x 585 μ m	55 x 700 μ m	70 x 960 μ m
	EMR	64 x 400 μ m	125 x 835 μ m	195 x 1200 μ m	300 x 1940 μ m
Light source		semiconductor laser <1mW, 670nm (red)			
Laser safety class		class 2 acc. DIN EN 60825-1/A1 12.99 / IEC 825-1/A1 12.99 / FDA			
Protection class		sensor: IP 65 / controller: IP 50			
Temperature stability		0.025% FSO/ $^{\circ}$ C	0.01 % FSO/ $^{\circ}$ C		
Operation temperature		0 ... +50 $^{\circ}$ C			
Storage temperature		-20 ... +70 $^{\circ}$ C			
Output		analogue: ± 5 V digital: RS 422 / 691.2kBaud			
Power supply		24VDC ($\pm 15\%$), max. 500mA			
Sensor cable length		standard: 2m - integrated option: 5m/10m			
Controller		functions: auto zero / signal averaging dimensions: 143mm x 145mm x 52mm - without mounting clips			
Electromagnetic compatibility (EMC)		EN 55011/12.1998 and EN 50082-2/02.1996			
Vibration		2g / 20 ... 500Hz			
Shock		15g / 6ms / 3 axis			
Weight		sensor: ~550g controller: ~1000g			

FSO = Full Scale Output SMR = Start of measuring range MMR = Midrange EMR = End of measuring range
All specifications apply for a diffusely reflecting white ceramic target

¹⁾ for measurements against high glossy surfaces (targets), resolution depends on the material

²⁾ resolution digital output 16bit

Custom Sensor Modifications

For applications where the above standard sensors do not meet your requirements, it may be possible to supply a sensor with modified specification. Please contact us for further information.

Options

- Non standard measuring range and stand off
- Custom housing or mounting geometry
- Measuring rate 2.5 / 5 / 10 / 20kHz
- Non standard signal interfaces
- Special cable length of electrical connector
- 90° beam deflection
- Vacuum suitability
- Reduced mass
- Increased shock and vibration resistance

High performance sensors made by Micro-Epsilon



Sensors and systems for displacement, position and dimension

Eddy current sensors
Optical and laser sensors
Capacitive sensors
Inductive sensors
Draw-wire sensors
Optical micrometers
2D/3D profile sensors
Image processing



Sensors and measurement devices for non-contact temperature sensors

Online instruments
Handheld devices

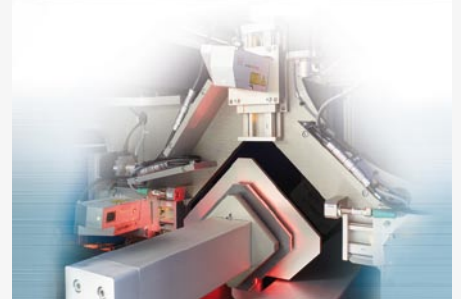

Measuring systems for quality control

for plastic and film
for tire and rubber
for web material
for automotive components
for glass