



optoNCDT Options



LASERSTRAHLUNG
NICHT IN DEN STRAHL BLICKEN
nach DIN EN 60825-1:2001-11
P<1 mW, λ = 670 nm

optoNCDT 1710-200 / 1720-200 / 1700-300	3
optoNCDT 1700-10(006)	4
optoNCDT 1700-120	5
optoNCDT 1700-120/90	6
optoNCDT 1700-200(015)	7
optoNCDT 2200-2(235)	8
optoNCDT 2200-20(223)	9
optoNCDT 2200-22(236)LL90	10
optoNCDT 2200-22(241)LL90	11
optoNCDT 2200-30	12
optoNCDT 2200-60	13
optoNCDT 2200-100(210)	14
optoNCDT 2200-100(237)	15
optoNCDT 2200-200(230)	16
optoNCDT 2200-500	17
optoNCDT 2220-20(204)	18
optoNCDT 2210-20(242)/90	19
optoNCDT 1700Z-10	20

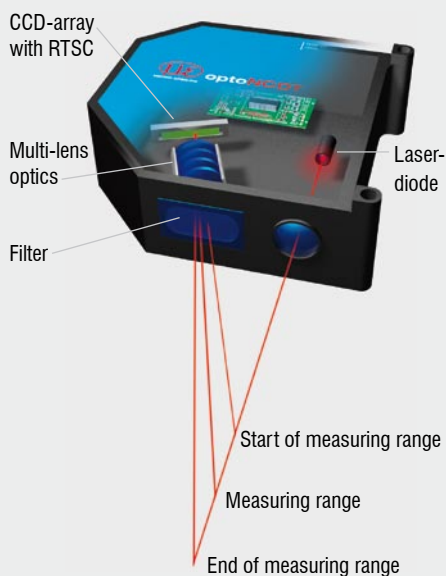

Leadership in laser displacement measurement

Micro-Epsilon has a long-standing success of developing laser displacement sensors. Already a pioneer in the field of CCD sensors, Micro-Epsilon has continually raised the bar in industrial laser displacement measurement.

Measurement principle: Laser triangulation

Laser triangulation sensors operate with a laser diode which projects a visible light spot onto the surface of the measurement target. The light reflected from the spot is imaged by an optical receiving system onto a position-sensitive element. If the light spot changes its position, this change is imaged on the receiving element and evaluated. With the 1607 Series an analogue PSD module is used as the position-sensitive measuring element, whereas with the remaining sensors CMOS elements and CCD elements are used.



LASER RADIATION
Do not stare into the beam
CLASS 2 LASER PRODUCT
IEC 60825-1: 2001-11
P<1mW; λ=670nm

IEC - Standard

Custom Sensor Modifications

For applications where the above standard sensors do not meet your requirements, it may be possible to supply a sensor with modified specifications:

- Measuring range and stand off
- Custom housing or mounting geometry
- Measuring rate 2.5 / 5 / 10 / 20kHz
- Non standard signal interfaces
- Special cable length of electrical connector
- 90° beam deflection
- Vacuum suitability
- Reduced mass
- Increased shock and vibration resistance

optoNCDT sensors uses a semiconductor laser with a wavelength of 670nm (visible/red). The maximum optical output power is 1mW. The sensor is classified as laser class II. A warning sign is attached to the sensor housing.

Dimensions

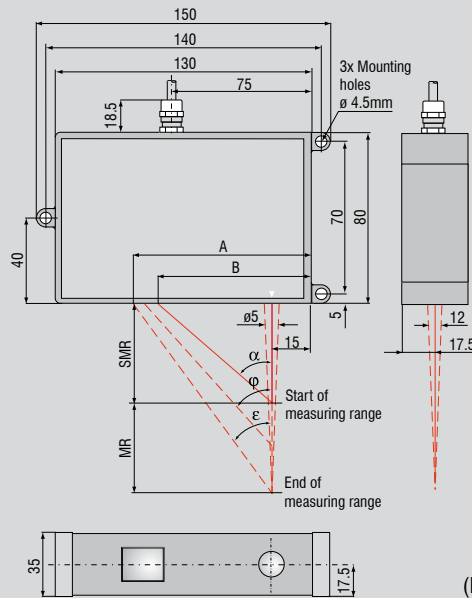

Model	MR	SMR	α	ϕ	ϵ	A	B
ILD1710-200(227)	200	250	15.6°	12.6°	10.8°	101	86
ILD1720-200(220)	200	130	28.3°	18.7°	14.6°		
ILD1700-300(227)	300	200	19.3°	12.6°	9.8°		

Model	ILD1710-200	ILD1720-200	ILD1700-300
Article no.	4120098	4120099	4120157
Measuring range	200mm	200mm	300mm
Start of measuring range (SMR)	250mm	130mm	200mm
Midrange (MMR)	350mm	230mm	350mm
End of measuring range (EMR)	450mm	330mm	500mm
Linearity ($\leq \pm 0.08\%$ FSO)	160 μ m	160 μ m	240 μ m
Spot diameter	SMR	1500 μ m	1500 μ m
	MMR	1500 μ m	1500 μ m
	EMR	1500 μ m	1500 μ m
Resolution (at 2.5kHz without averaging)	12 μ m	12 μ m	18 μ m
Measuring rate (adjustable)	2.5kHz / 1.25kHz / 625Hz / 312.5Hz		
Light source	semiconductor laser < 1mW, 670nm (red)		
Permissible ambient light (at 2.5kHz)	10,000lx		
Laser safety class	class 2 IEC 60825-1 : 2001-11		
Temperature stability*	0.01% FSO/°C		
Operation temperature	0°C ... +50°C		
Storage temperature	-20°C ... +70°C		
Measurement outputs (selectable)	4 ... 20mA / 0 ... 10V / RS 422 / USB (option with cable PC1700-3/USB)		
Switching outputs (programmable)	1 x error or 2 x limit		
Switch input (configurable)	Laser ON-OFF, Zero, Trigger/Sync		
Operation	via touch screen on sensor or via PC with ILD 1700 tool		
Power supply	24VDC (11 ... 30VDC), max. 150mA		
Electromagnetic compatibility (EMC)	EN 61000-6-3; EN 61000-6-2		
Sensor cable length (with connector)	standard 0.25m integrated		
Further functions (programmable)	Synchronisation possible for simultaneous or alternating measurements, Trigger possible		
Protection class	IP 65		
Vibration	2g / 20 ... 500Hz (IEC 68-2-6)		
Shock	15g / 6ms (IEC 68-2-29)		
Weight (with 25cm cable)	appr. 600 g		

FSO = Full scale output All specifications apply for a diffusely reflecting matt white ceramic target

*based to digital output

SMR = Start of measuring range; MMR = Midrange; EMR = End of measuring range

Dimensions

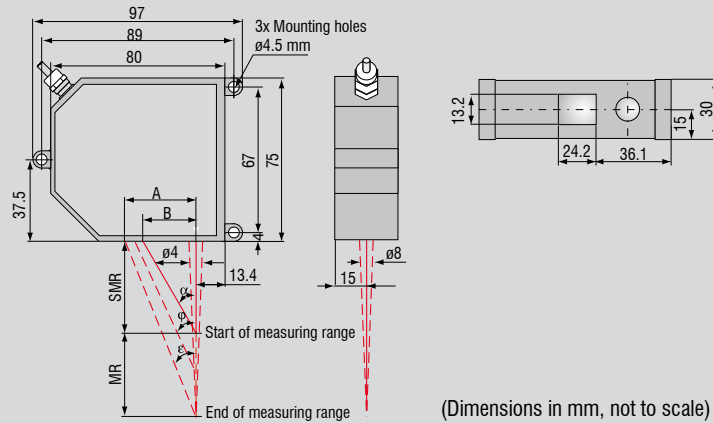

Model	ILD 1700-120	
Measuring range	130mm	
Start of measuring range	70mm	
Midrange	135mm	
End of measuring range	200mm	
Linearity	≤ ±0.08% FSO	100μm
Resolution (at 2.5kHz without averaging)	6μm	
Measuring rate	2.5kHz / 1.25kHz / 625Hz / 312.5Hz (adjustable)	
Light source	semiconductor laser < 1mW, 670nm (red)	
Permissible ambient light (at 2.5kHz)	10,000lx	
Laser safety class	class 2 IEC 60825-1 : 2001-11	
Spot diameter	SMR 740μm; MMR 60μm; EMR 700μm	
Temperature stability*	0.01% FSO/°C	
Operation temperature	0°C ... +50°C	
Storage temperature	-20°C ... +70°C	
Output	measurements	selectable: 4 ... 20mA / 0 ... 10V / RS 422 / USB (option with cable PC1700-3/USB)
	switching outputs	1 x error or 2 x limit (each programmable)
Switch input	Laser ON-OFF / Zero	
Operation	via touch screen on sensor or via PC with ILD 1700 tool	
Power supply	24VDC (11 ... 30VDC), max. 150mA	
Electromagnetic compatibility (EMC)	EN 61000-6-3; EN 61000-6-2	
Sensor cable length (with connector)	standard 0.25m integrated / optional: extension 3m or 10m	
Synchronisation	possible for simultaneous or alternating measurements	
Protection class	IP 65	
Vibration	2g / 20 ... 500Hz	
Shock	15g / 6ms	
Weight (with 25cm cable)	appr. 550g	

FSO = Full scale output All specifications apply for a diffusely reflecting matt white ceramic target

*based to digital output

SMR = Start of measuring range MMR = Midrange EMR = End of measuring range

Dimensions

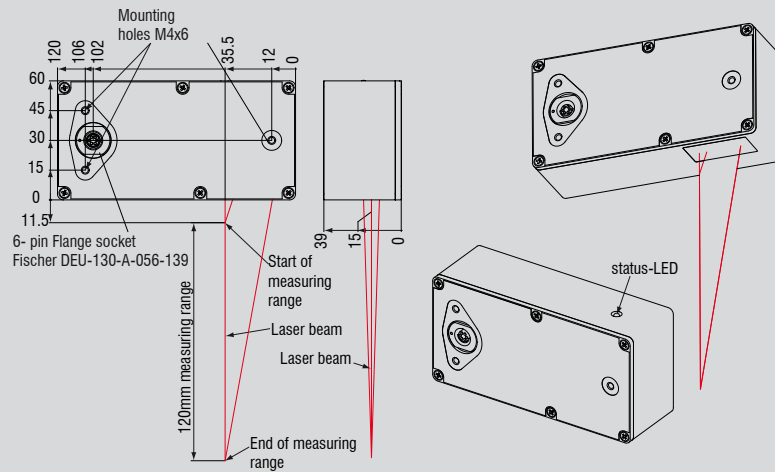

(Dimensions in mm, not to scale)

Model	ILD 1700-120/90	
Measuring range	120mm	
Start of measuring range	11.5mm	
Midrange	71.5mm	
End of measuring range	131.5mm	
Linearity	$\leq \pm 0.08\%$ FSO	100 μm
Resolution (at 2.5kHz without averaging)	6 μm	
Measuring rate	2.5kHz / 1.25kHz / 625Hz / 312.5Hz (adjustable)	
Light source	semiconductor laser < 1mW, 670nm (red)	
Permissible ambient light (at 2.5kHz)	10,000lx	
Laser safety class	class 2 IEC 60825-1 : 2001-11	
Spot diameter	SMR 740 μm ; MMR 60 μm ; EMR 700 μm	
Temperature stability*	0.01% FSO/ $^{\circ}\text{C}$	
Operation temperature	0 $^{\circ}\text{C}$... +50 $^{\circ}\text{C}$	
Storage temperature	-20 $^{\circ}\text{C}$... +70 $^{\circ}\text{C}$	
Output	measurements	selectable: 4 ... 20mA / 0 ... 10V / RS 422 / USB (option with cable PC1700-3/USB)
	switching outputs	1 x error or 2 x limit (each programmable)
Switch input	Laser ON-OFF / Zero	
Operation	via touch screen on sensor or via PC with ILD 1700 tool	
Power supply	24VDC (11 ... 30VDC), max. 150mA	
Electromagnetic compatibility (EMC)	EN 61000-6-3; EN 61000-6-2	
Sensor cable length (with connector)	standard 0.25m integrated / optional: extension 3m or 10m	
Synchronisation	possible for simultaneous or alternating measurements	
Protection class	IP 65	
Vibration	2g / 20 ... 500Hz	
Shock	15g / 6ms	
Weight (with 25cm cable)	appr. 550g	

FSO = Full scale output All specifications apply for a diffusely reflecting matt white ceramic target

*based to digital output ; SMR = Start of measuring range MMR = Midrange EMR = End of measuring range

Dimensions

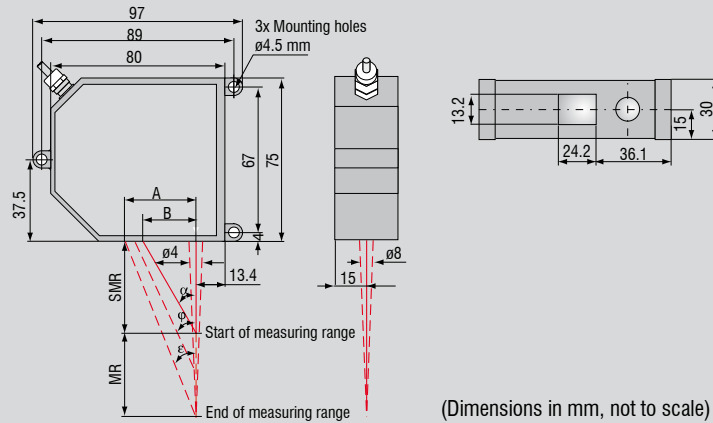

Model	ILD1700-200(015)	
Measuring range	205mm	
Start of measuring range	100mm	
Midrange	200mm	
End of measuring range	300mm	
Linearity	≤ ±0.08% FSO	160μm
Resolution (at 2.5kHz without averaging)	10μm	
Measuring rate	2.5kHz / 1.25kHz / 625Hz / 312.5Hz (adjustable)	
Light source	semiconductor laser < 1mW, 670nm (red)	
Permissible ambient light (at 2.5kHz)	10,000lx	
Laser safety class	class 2 IEC 60825-1 : 2001-11	
Spot diameter	SMR 740μm; MMR 60μm; EMR 700μm	
Temperature stability*	0.01% FSO/°C	
Operation temperature	0 ... +50°C	
Storage temperature	-20 ... +70°C	
Output	measurements	selectable: 4 ... 20mA / 0 ... 10V / RS 422 / USB (option with cable PC1700-3/USB)
	switching outputs	1 x error or 2 x limit (each programmable)
Switch input	Laser ON-OFF / Zero	
Operation	via touch screen on sensor or via PC with ILD 1700 tool	
Power supply	24VDC (11 ... 30VDC), max. 150mA	
Electromagnetic compatibility (EMC)	EN 61000-6-3; EN 61000-6-2	
Sensor cable length (with connector)	standard 0.25m integrated / optional: extension 3m or 10m	
Synchronisation	possible for simultaneous or alternating measurements	
Protection class	IP 65	
Vibration	2g / 20 ... 500Hz	
Shock	15g / 6ms	
Weight (with 25cm cable)	appr. 550g	

FSO = Full scale output All specifications apply for a diffusely reflecting matt white ceramic target

*based to digital output

SMR = Start of measuring range MMR = Midrange EMR = End of measuring range

Dimensions

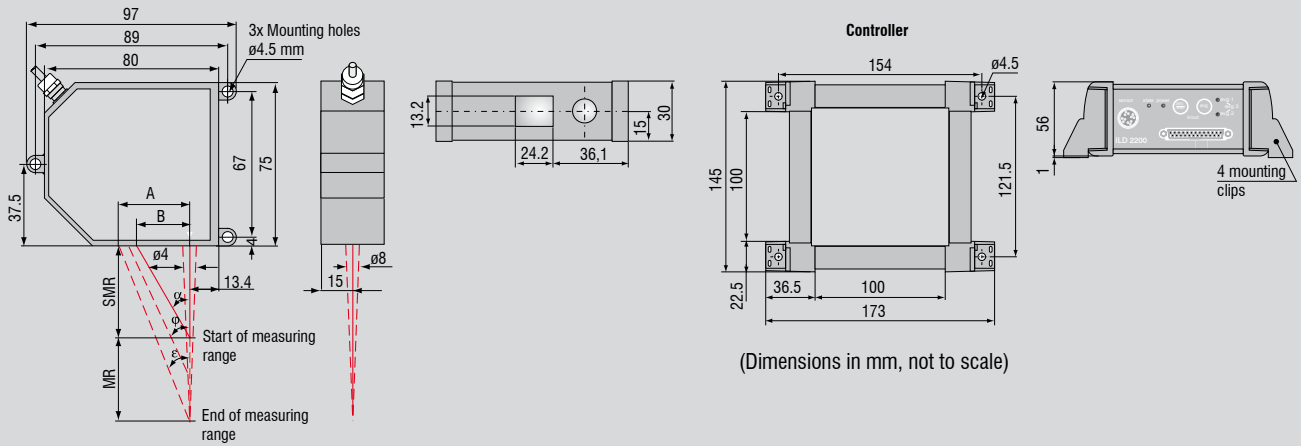

Model	ILD 2200-20(235)	
Measuring range	2mm (other measuring ranges on request)	
Start of measuring range	24mm	
Midrange	25mm	
End of measuring range	26mm	
Linearity	$\leq \pm 0.08\%$ FSO	1 μ m
Resolution (at 10kHz without averaging)	0.0015% FSO	0.03 μ m
Measuring rate	10kHz	
Permissible ambient light	30,000lx	
Spot diameter	SMR 80 μ m; MMR 35 μ m; EMR 80 μ m;	
Light source	semiconductor laser <1mW, 670nm (red)	
Laser safety class 2	DIN EN 60825-1/A1 12.99 / IEC 825-1/A1 12.99 / FDA	
Protection class	sensor: IP 40 / controller: IP 50	
Temperature stability	0.01% FSO/ $^{\circ}$ C	
Operation temperature	0 ... +50 $^{\circ}$ C	
Storage temperature	-20 ... +70 $^{\circ}$ C	
Output	analogue	± 5 V
	digital	RS 422 / 691.2kBaud
Power supply	24VDC ($\pm 15\%$), max. 500mA	
Sensor cable	modified cable 3m with connector for vacuum feed through ¹⁾	
Controller	functions: auto zero / signal averaging	
Electromagnetic compatibility (EMC)	EN 55011/12.1998 and EN 50082-2/ 02.1996	
Vibration	2g / 20 ... 500Hz	
Shock	15g / 6ms / 3 axis	

FSO = Full scale output All specifications apply for a diffusely reflecting matt white ceramic target

SMR = Start of measuring range MMR = Midrange EMR = End of measuring range

¹⁾ Vacuum feed through and cable are included in delivery

Dimensions

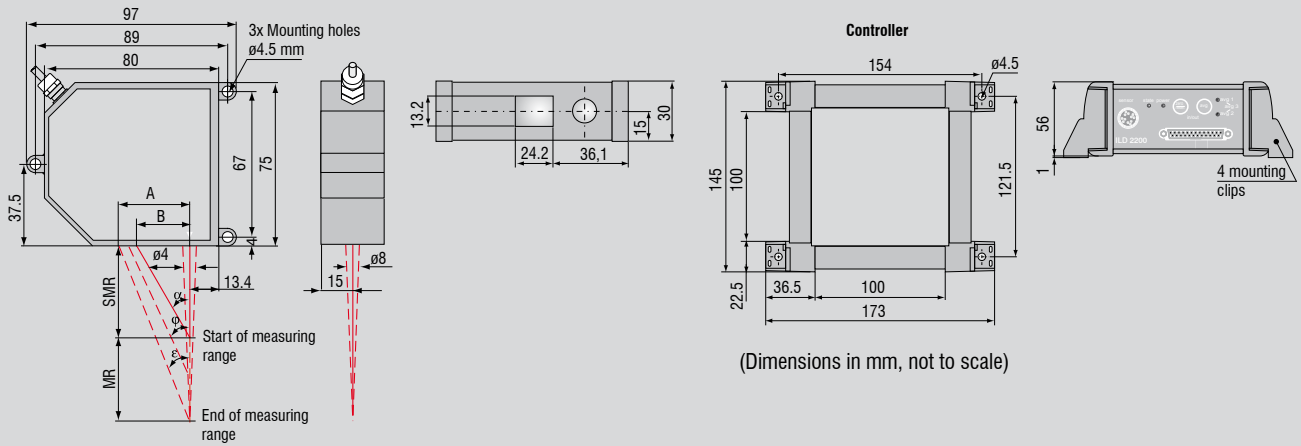

Model	ILD 2200-20(223)	
Measuring range		20mm
Start of measuring range		40mm
Midrange		50mm
End of measuring range		60mm
Linearity	$\leq \pm 0.03\%$ FSO	$6\mu\text{m}$
Resolution (at 10kHz without averaging)	0.0015% FSO	$0.3\mu\text{m}$
Measuring rate		10kHz
Permissible ambient light		30,000lx
Spot diameter		SMR $160\mu\text{m}$; MMR $60\mu\text{m}$; EMR $160\mu\text{m}$;
Light source		semiconductor laser $< 1\text{mW}$, 670nm (red)
Laser safety class 2		DIN EN 60825-1/A1 12.99 / IEC 825-1/A1 12.99 / FDA
Protection class		sensor: IP 65 / controller: IP 50
Temperature stability		0.01% FSO/ $^{\circ}\text{C}$
Operation temperature		$0 \dots +50^{\circ}\text{C}$
Storage temperature		$-20 \dots +70^{\circ}\text{C}$
Output	analogue	$\pm 5\text{V}$
	digital	RS 422 / 691.2kBaud
Power supply		24VDC ($\pm 15\%$), max. 500mA
Sensor cable		standard: 2m - integrated ; option: 5m/10m
Controller		functions: auto zero / signal averaging
Electromagnetic compatibility (EMC)		EN 55011/12.1998 and EN 50082-2/ 02.1996
Vibration		2g / 20 ... 500Hz
Shock		15g / 6ms / 3 axis

FSO = Full scale output All specifications apply for a diffusely reflecting matt white ceramic target

*based to digital output

SMR = Start of measuring range MMR = Midrange EMR = End of measuring range

Dimensions

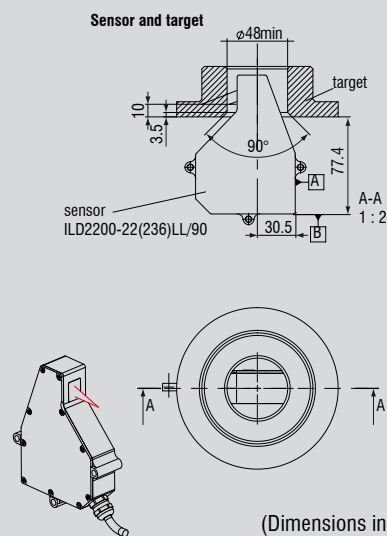
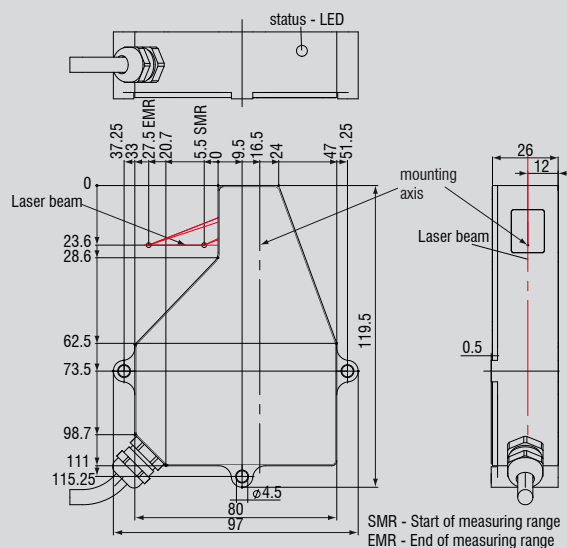

(Dimensions in mm, not to scale)

Model	ILD 2200-22(236)LL90	
Measuring range		22 mm
Start of measuring range		5.5mm
Midrange		16.5mm
End of measuring range		27.5mm
Linearity	$\leq \pm 0.03\%$ FSO	7 μ m
Resolution (at 10kHz without averaging)	0.0015% FSO	0.4 μ m
Measuring rate		2.5kHz
Permissible ambient light		10,000lx
Spot diameter		SMR 160 μ m; MMR 60 μ m; EMR 160 μ m;
Light source		semiconductor laser <1mW, 670nm (red)
Laser safety class 2		DIN EN 60825-1/A1 12.99 / IEC 825-1/A1 12.99 / FDA
Protection class		sensor: IP 65 / controller: IP 50
Temperature stability		0.01% FSO/ $^{\circ}$ C
Operation temperature		0 ... +50 $^{\circ}$ C
Storage temperature		-20 ... +70 $^{\circ}$ C
Output	digital	RS 485 / 115.2kBaud
Power supply		24VDC ($\pm 15\%$), max. 500mA
Sensor cable		standard: 0.3m (integrated) ; option: 5.3m/10.3m
Controller		functions: auto zero / signal averaging dimensions: 143mm x 145mm x 52mm
Electromagnetic compatibility (EMC)		EN 55011/12.1998 and EN 50082-2/ 02.1996
Vibration		2g / 20 ... 500Hz
Shock		15g / 6ms / 3 axis

FSO = Full scale output

All specifications apply for a diffusely reflecting matt white ceramic target

SMR = Start of measuring range MMR = Midrange EMR = End of measuring range

Dimensions

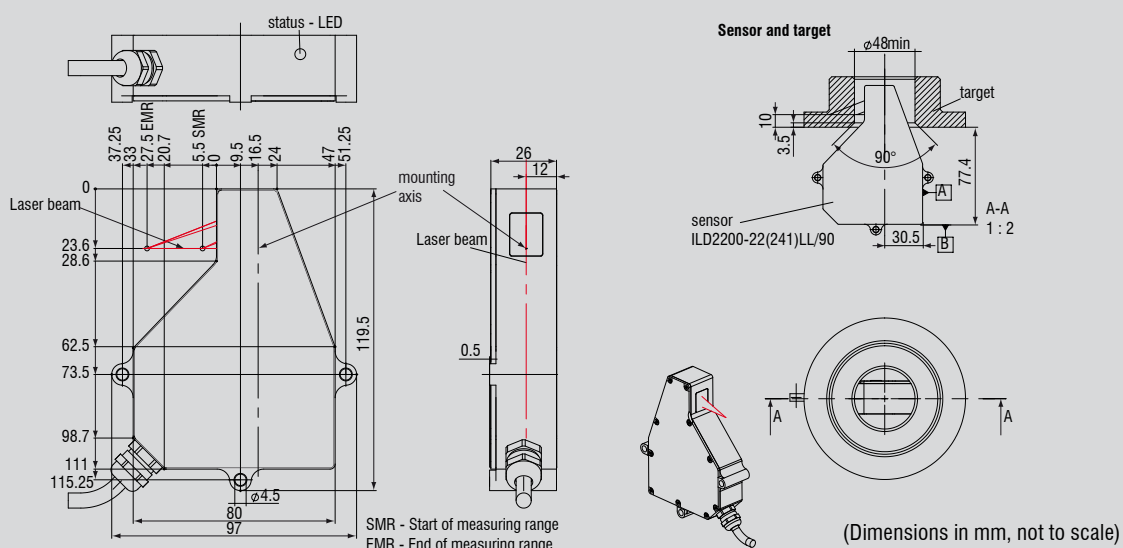

Model	ILD 2200-22(241)LL90	
Measuring range	22mm	
Start of measuring range	5.5mm	
Midrange	16.5mm	
End of measuring range	27.5mm	
Linearity	$\leq \pm 0.03\%$ FSO	7 μ m
Resolution (at 10kHz without averaging)	0.0015% FSO	0.4 μ m
Measuring rate	10kHz	
Permissible ambient light	10,000lx	
Spot diameter	SMR 160 μ m; MMR 60 μ m; EMR 160 μ m;	
Light source	semiconductor laser <1mW, 670nm (red)	
Laser safety class 2	DIN EN 60825-1/A1 12.99 / IEC 825-1/A1 12.99 / FDA	
Protection class	sensor: IP 65 / controller: IP 50	
Temperature stability	0.01% FSO/ $^{\circ}$ C	
Operation temperature	0 ... +50 $^{\circ}$ C	
Storage temperature	-20 ... +70 $^{\circ}$ C	
Output	analogue	± 5 V
	digital	RS485 / 115.2kBaud
Power supply	24VDC ($\pm 15\%$), max. 500mA	
Sensor cable	standard: 2m (integrated)	
Controller	functions: auto zero / signal averaging; dimensions: 143mm x 145mm x 52mm	
Electromagnetic compatibility (EMC)	EN 55011/12.1998 and EN 50082-2/ 02.1996	
Vibration	2g / 20 ... 500 Hz	
Shock	15g / 6ms / 3 axis	

FSO = Full scale output

All specifications apply for a diffusely reflecting matt white ceramic target

SMR = Start of measuring range MMR = Midrange EMR = End of measuring range

Dimensions

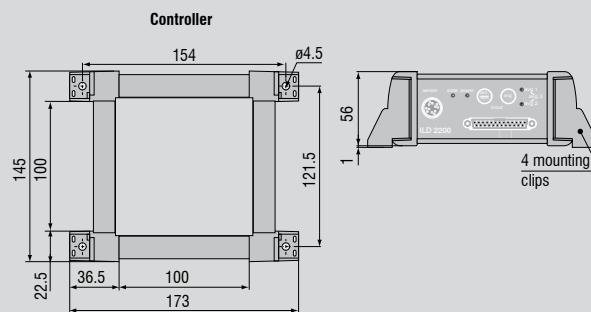
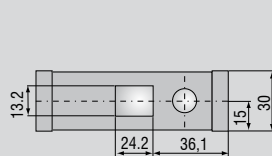
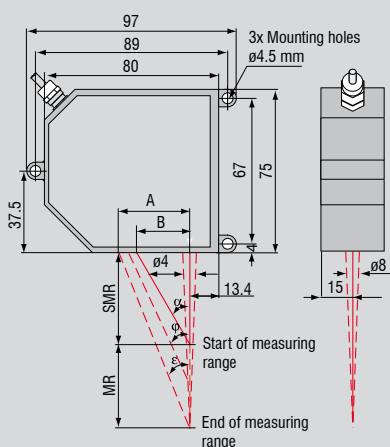

(Dimensions in mm, not to scale)

Model	ILD 2200-30	
Measuring range		30mm
Start of measuring range		30mm
Midrange		45mm
End of measuring range		60mm
Linearity	$\leq \pm 0.03\% \text{ FSO}$	$9\mu\text{m}$
Resolution (at 10kHz without averaging)	$0.0015\% \text{ FSO}$	$0.4\mu\text{m}$
Measuring rate		10kHz
Permissible ambient light		30,000lx
Spot diameter		SMR $160\mu\text{m}$; MMR $60\mu\text{m}$; EMR $160\mu\text{m}$;
Light source		semiconductor laser $< 1\text{mW}$, 670nm (red)
Laser safety class 2		DIN EN 60825-1/A1 12.99 / IEC 825-1/A1 12.99 / FDA
Protection class		sensor: IP 65 / controller: IP 50
Temperature stability		$0.01\% \text{ FSO}/^\circ\text{C}$
Operation temperature		$0^\circ\text{C} \dots +50^\circ\text{C}$
Storage temperature		$-20^\circ\text{C} \dots +70^\circ\text{C}$
Output	analogue	$\pm 5\text{V}$
	digital	RS 422 / 691.2kBaud
Power supply		24VDC ($\pm 15\%$), max. 500mA
Sensor cable		standard: 2m (integrated); option: 5m/10m
Controller		functions: auto zero / signal averaging
Electromagnetic compatibility (EMC)		EN 55011/12.1998 and EN 50082-2/ 02.1996
Vibration		2g / 20 ... 500Hz
Shock		15g / 6ms / 3 axis

FSO = Full scale output

All specifications apply for a diffusely reflecting matt white ceramic target

SMR = Start of measuring range MMR = Midrange EMR = End of measuring range

Dimensions

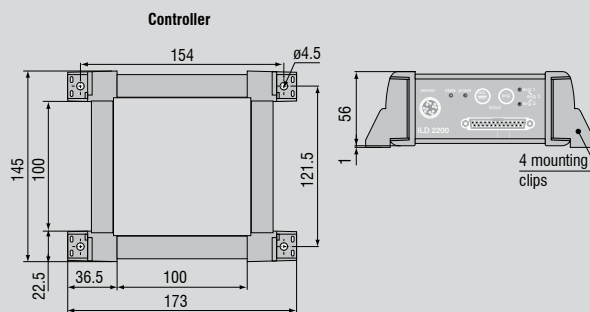
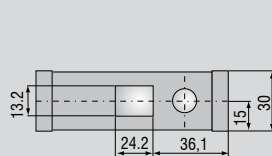
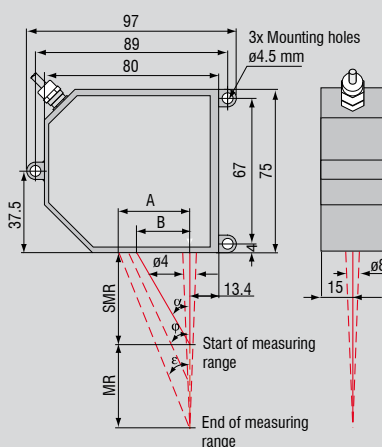

(Dimensions in mm, not to scale)

Model	ILD 2200-60	
Measuring range		60mm
Start of measuring range		45mm
Midrange		75mm
End of measuring range		105mm
Linearity	$\leq \pm 0.03\% \text{ FSO}$	18 μm
Resolution (at 10kHz without averaging)	0.0015% FSO	0.9 μm
Measuring rate		10kHz
Permissible ambient light		30,000lx
Spot diameter		SMR 160 μm ; MMR 60 μm ; EMR 160 μm ;
Light source		semiconductor laser <1mW, 670nm (red)
Laser safety class 2		DIN EN 60825-1/A1 12.99 / IEC 825-1/A1 12.99 / FDA
Protection class		sensor: IP 65 / controller: IP 50
Temperature stability		0.01% FSO/ $^{\circ}\text{C}$
Operation temperature		0 ... +50 $^{\circ}\text{C}$
Storage temperature		-20 ... +70 $^{\circ}\text{C}$
Output	analogue	$\pm 5\text{V}$
	digital	RS 422 / 691.2kBaud
Power supply		24VDC ($\pm 15\%$), max. 500mA
Sensor cable		standard: 2m (integrated); option: 5m/10m
Controller		functions: auto zero / signal averaging
Electromagnetic compatibility (EMC)		EN 55011/12.1998 and EN 50082-2/ 02.1996
Vibration		2g / 20 ... 500Hz
Shock		15g / 6ms / 3 axis

FSO = Full scale output

All specifications apply for a diffusely reflecting matt white ceramic target

SMR = Start of measuring range MMR = Midrange EMR = End of measuring rang

Dimensions

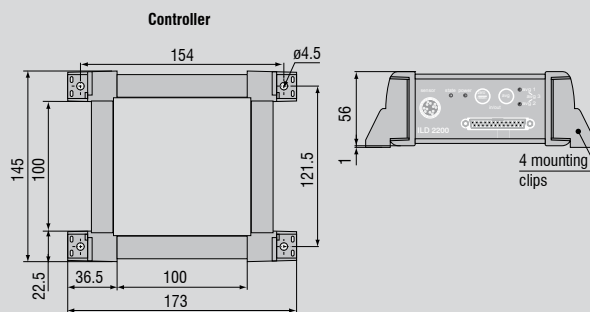
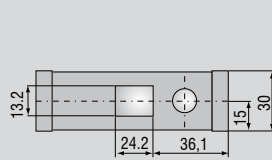
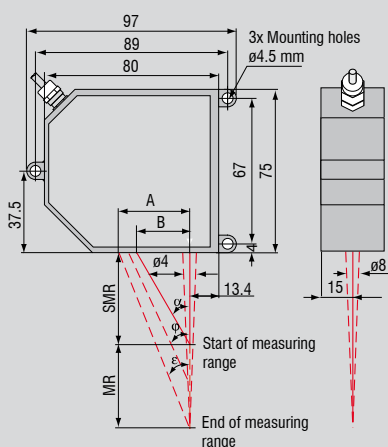

(Dimensions in mm, not to scale)

Model	ILD 2200-100(210)	
Measuring range		100mm
Start of measuring range		70mm
Midrange		120mm
End of measuring range		170mm
Linearity	$\leq \pm 0.03\% \text{ FSO}$	$30 \mu\text{m}$
Resolution (at 10kHz without averaging)	$0.0015\% \text{ FSO}$	$1.5 \mu\text{m}$
Measuring rate		2.5kHz
Permissible ambient light		10,000lx
Spot diameter		SMR $350 \mu\text{m}$; MMR $130 \mu\text{m}$; EMR $350 \mu\text{m}$;
Light source		semiconductor laser $< 1 \text{ mW}$, 670nm (red)
Laser safety class 2		DIN EN 60825-1/A1 12.99 / IEC 825-1/A1 12.99 / FDA
Protection class		sensor: IP 65 / controller: IP 50
Temperature stability		$0.01\% \text{ FSO}/^\circ\text{C}$
Operation temperature		$0^\circ\text{C} \dots +50^\circ\text{C}$
Storage temperature		$-20^\circ\text{C} \dots +70^\circ\text{C}$
Output	analogue	$\pm 5\text{V}$
Power supply		24VDC ($\pm 15\%$), max. 500mA
Sensor cable		standard: 2m (integrated); option: 5m/10m
Controller		functions: auto zero / signal averaging
Electromagnetic compatibility (EMC)		EN 55011/12.1998 and EN 50082-2/ 02.1996
Vibration		2g / 20 ... 500Hz
Shock		15g / 6ms / 3 axis

FSO = Full scale output

All specifications apply for a diffusely reflecting matt white ceramic target

SMR = Start of measuring range MMR = Midrange EMR = End of measuring rang

Dimensions

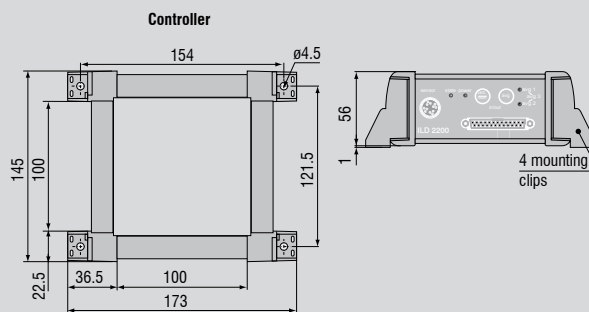
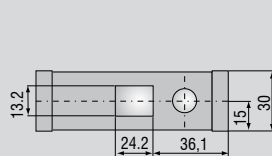
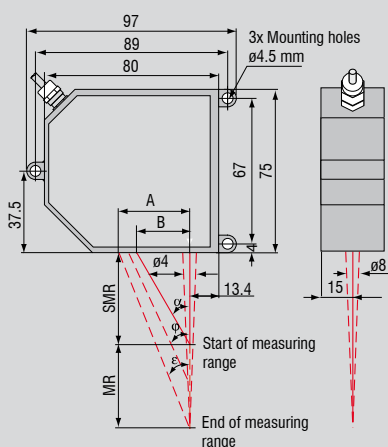

(Dimensions in mm, not to scale)

Model	ILD 2200-100(237)	
Measuring range		100mm
Start of measuring range		70mm
Midrange		120mm
End of measuring range		170mm
Linearity	$\leq \pm 0.03\% \text{ FSO}$	$30 \mu\text{m}$
Resolution (at 10kHz without averaging)	$0.0015\% \text{ FSO}$	$1.5 \mu\text{m}$
Measuring rate		2.5 kHz
Permissible ambient light		10,000lx
Spot diameter		SMR $350 \mu\text{m}$; MMR $130 \mu\text{m}$; EMR $350 \mu\text{m}$;
Light source		semiconductor laser $< 1 \text{ mW}$, 670nm (red)
Laser safety class 2		DIN EN 60825-1/A1 12.99 / IEC 825-1/A1 12.99 / FDA
Protection class		sensor: IP 65 / controller: IP 50
Temperature stability		$0.01\% \text{ FSO}/^\circ\text{C}$
Operation temperature		$0^\circ\text{C} \dots +50^\circ\text{C}$
Storage temperature		$-20^\circ\text{C} \dots +70^\circ\text{C}$
Output	analogue	$\pm 5 \text{V}$
	digital	RS 422 / 691.2kBaud
Power supply		24VDC ($\pm 15\%$), max. 500mA
Sensor cable		standard: 2m (integrated); option: 5m/10m
Controller		functions: auto zero / signal averaging
Electromagnetic compatibility (EMC)		EN 55011/12.1998 and EN 50082-2/ 02.1996
Vibration		2g / 20 ... 500Hz
Shock		15g / 6ms / 3 axis

FSO = Full scale output

All specifications apply for a diffusely reflecting matt white ceramic target

SMR = Start of measuring range MMR = Midrange EMR = End of measuring rang

Dimensions

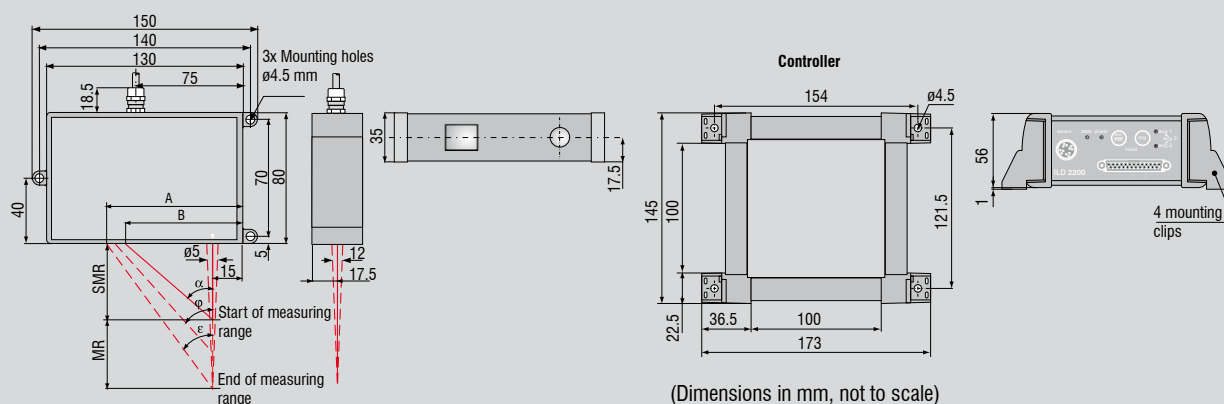

Model	ILD 2200-200(230)	
Measuring range		200mm
Start of measuring range		250mm
Midrange		350mm
End of measuring range		450mm
Linearity	$\leq \pm 0.03\% \text{ FSO}$	$60 \mu\text{m}$
Resolution (at 10kHz without averaging)	$0.0015\% \text{ FSO}$	$3 \mu\text{m}$
Measuring rate		10kHz
Permissible ambient light		30,000lx
Spot diameter		SMR $1300 \mu\text{m}$; MMR $1300 \mu\text{m}$; EMR $1300 \mu\text{m}$
Light source		semiconductor laser $< 1 \text{ mW}$, 670nm (red)
Laser safety class 2		DIN EN 60825-1/A1 12.99 / IEC 825-1/A1 12.99 / FDA
Protection class		sensor: IP 65 / controller: IP 50
Temperature stability		$0.01\% \text{ FSO}/^\circ\text{C}$
Operation temperature		$0 \dots +50^\circ\text{C}$
Storage temperature		$-20 \dots +70^\circ\text{C}$
Output	analogue	$\pm 5 \text{ V}$
	digital	RS 422 / 691.2kBaud
Power supply		24VDC ($\pm 15\%$), max. 500mA
Sensor cable		standard: 0.3m (integrated)
Controller		functions: auto zero / signal averaging
Electromagnetic compatibility (EMC)		EN 55011/12.1998 and EN 50082-2/ 02.1996
Vibration		2g / 20 ... 500Hz
Shock		15g / 6ms / 3 axis

FSO = Full scale output

All specifications apply for a diffusely reflecting matt white ceramic target

SMR = Start of measuring range MMR = Midrange EMR = End of measuring rang

Dimensions

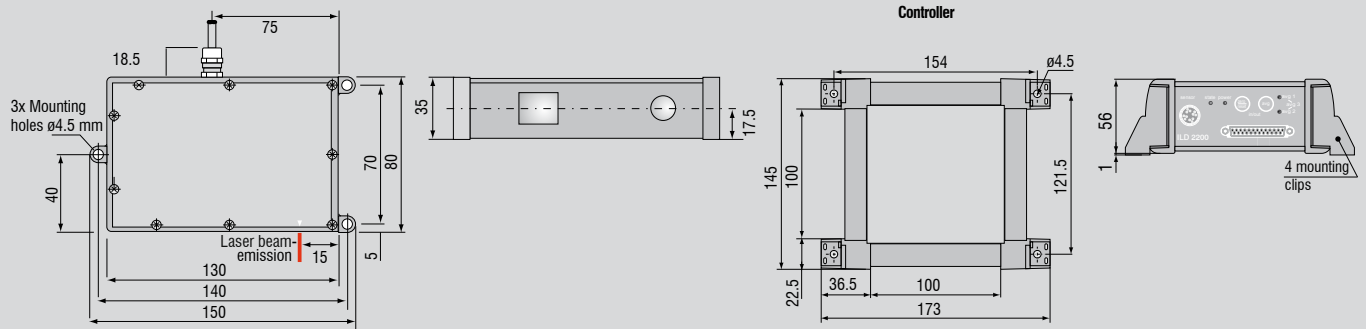

(Dimensions in mm, not to scale)

Model	ILD 2200-500	
Measuring range		500mm
Start of measuring range		200mm
Midrange		450mm
End of measuring range		700mm
Linearity	$\leq \pm 0.08\%$ FSO	$\pm 400\mu\text{m}$
Resolution	0.01 % FSO	50 μm (at 2.5kHz without averaging)
Measuring rate		10kHz
Permissible ambient light		10,000 lx
Spot diameter		1500 μm (option with smaller spot diameter)
Light source		semiconductor laser <1mW, 670nm (red)
Laser safety class 2		class 2 acc. DIN EN 60825-1 03.97 / IEC 825-1 11.93 / FDA
Protection class		sensor: IP 65 / controller: IP 50
Operation temperature		0 ... +50°C
Storage temperature		-20 ... +70°C
Output		standard: $\pm 5\text{ V}$ / option: RS 232 or RS 485
Power supply		24 VDC ($\pm 15\%$), max. 500mA
Sensor cable		standard: 2m (integrated); option: 5m/10m
Controller	functions	auto zero / signal averaging
	dimensions	143 x 145 x 52mm - without mounting clips
Weight		sensor 0.6kg / controller: 1.1kg
Electromagnetic compatibility (EMC)		EN 50081-1 and EN 50082-2
Vibration		2 g / 20 ... 500Hz
Shock		15 g / 6ms

FSO = Full scale output

Dimensions

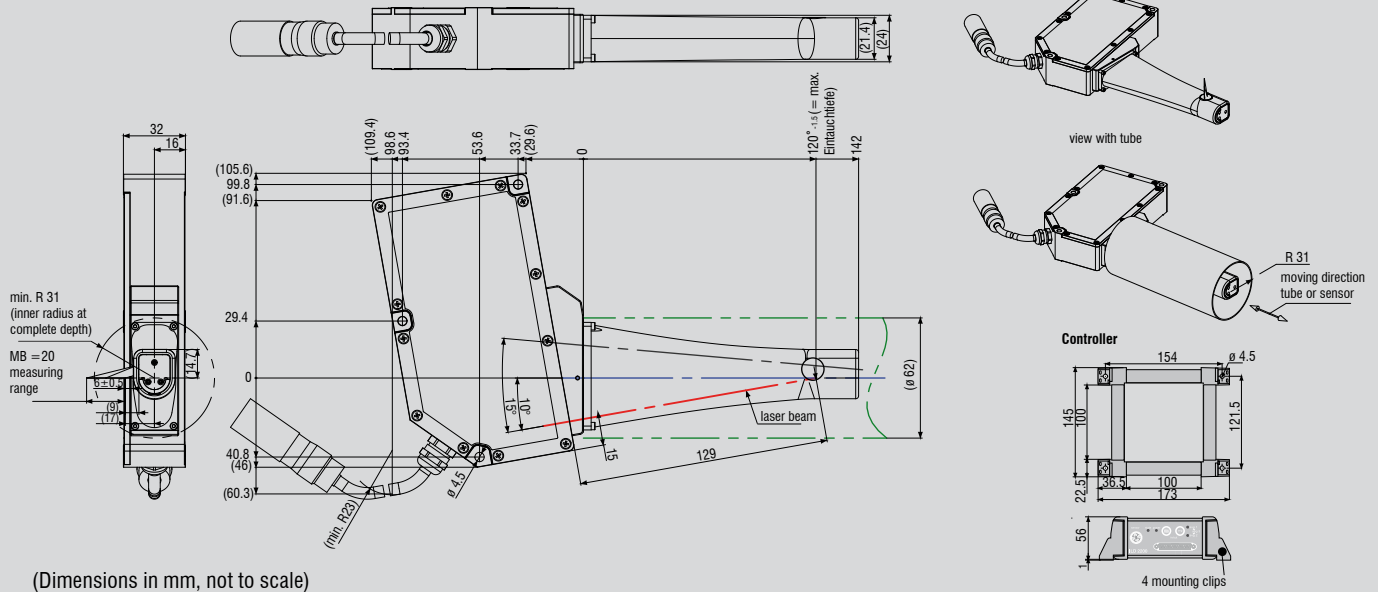

Model	ILD 2210-20(242)/90	
Measuring range	20mm	
Start of measuring range	SMR	6mm to laser output
Linearity	± 6µm ≤ ± 0.03% FSO	
Measuring rate	10kHz	
Permissible ambient light	30,000lx	
Spot diameter	SMR	130µm
	MMR	60µm
	EMR	130µm
Light source	semiconductor laser < 1mW, 670nm (red)	
Laser safety class 2	class 2 acc. DIN EN 60825-1 : 2001-11 / Class 2 (IEC 60825-1) Class II (FDA)	
Protection class	sensor: IP 65 / controller: IP 50	
Temperature stability	0.01% FSO/°C	
Operation temperature	0 ... 50°C	
Storage temperature	-20 ... 70°C	
Output	digital	RS 485 / 687.5kBaud
Power supply	24VDC (± 15%), max. 500mA	
Sensor cable	standard: 2m (integrated)	
Controller (separate)	controller with aluminium housing IP50 functions: auto zero / signal averaging dimensions (mm): 143 x 145 x 52 - without mounting clips	

FSO = Full scale output

All specifications apply for a diffusely reflecting matt white ceramic target

SMR = Start of measuring range MMR = Midrange EMR = End of measuring range

Dimensions

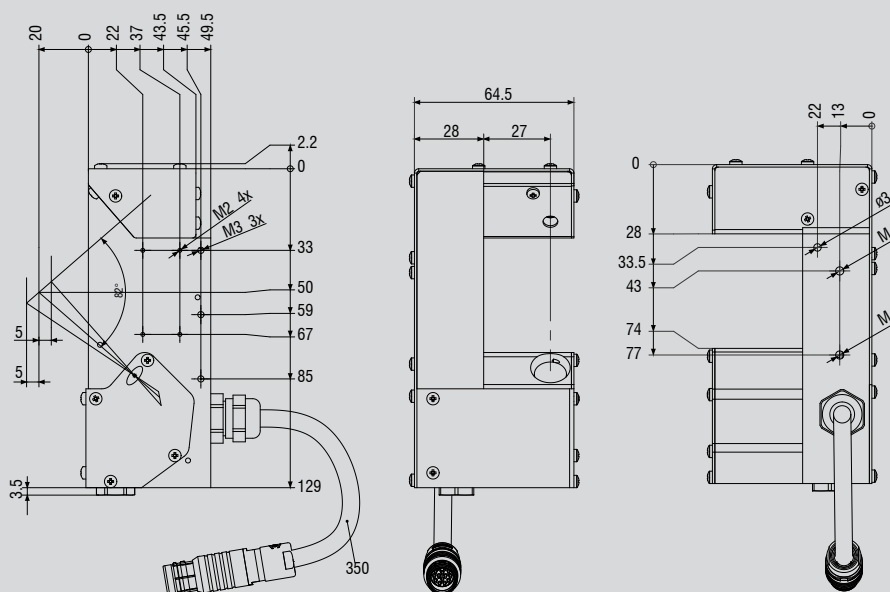

(Dimensions in mm, not to scale)

Mounting holes M4 (15mm deep); aligning pin \varnothing 3mm (2mm high)

Model	ILD1700Z-10
Measuring range (diffuse reflexion)	10mm
Measuring range (mirror reflexion)	5mm
Start of measuring range	15mm ¹⁾
Midrange	20mm ¹⁾
End of measuring range	25mm ¹⁾
Linearity	$\pm 0.1\%$ FSO
Resolution (at 2.5kHz without averaging)	0.5 μ m
Measuring rate	2.5kHz, 1.25kHz/ 625Hz/ 312.5Hz (adjustable)
Averaging	median, recursive, gliding (switchable)
Light source	semiconductor laser <1mW, 670nm (red)
Laser safety class	class 2 IEC 60825-1 : 2001-11
Spot diameter	SMR: 200 μ m; MMR: 50 μ m; EMR: 200 μ m
Permissible ambient light	10,000lx
Connector	35cm integrated cable with 14-pin. circular connector
Housing dimensions (mm)	129 x 64.5 x 50.5mm
Temperature stability (zero point)	0.01% FSO/ $^{\circ}$ C
Operation temperature	0 $^{\circ}$ C... +50 $^{\circ}$ C, dry
Storage temperature	-20 $^{\circ}$ C...70 $^{\circ}$ C, dry
Protection class	IP20
Vibration (IEC 60068-2-6)	2g/ 20...500Hz
Shock (IEC 60068-2-29)	15g/ 6ms
Output	measurements switching outputs
	selectable: 4 ... 20mA / 0 ... 10V / RS 422 / USB 1 x error or 2 x limit (configurable)
Power supply	11...30VDC, 150mA
Weight	500g (with connector cable and connector)

¹⁾ Related to the bottom edge of the sensor housing

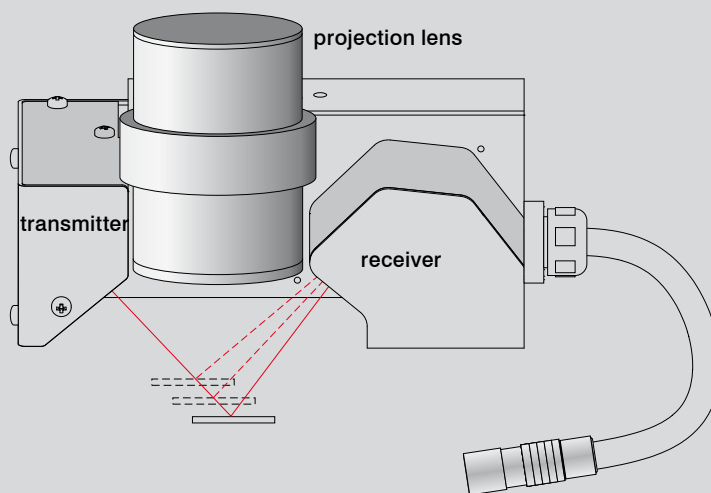

The sensor ILD1700Z-10 is designed for displacement measurement in direct reflection (mirror reflection). The sensor consists of a massive housing for the transmitter and the receiver including sheet covering. There is a free space for the projection lens between the transmitter (laser diode) and the receiver. The complete measurement range of 10mm can only be achieved in the case of diffuse reflection. In the case of reflective targets a reduced measurement range of 5mm (± 2.5 mm related to the offset distance) applies.

Advantage

- High measuring rate for fast position detection
- High measuring accuracy and resolution
- Direct measurement against the relevant place of positioning
- Adjustable measuring rate
- Switchable filter functions

Pin	Description		colour
5	+U _B	supply voltage (11 ... 30VDC)	red
6	GND	system for power supply and switching signals (Laser on/off, Zero, Limits)	black
13	analog output	current 4 ... 20mA or voltage 0 ... 10V	coaxial inner conductor, white
14	AGND	reference potential for analog output	coaxial shield
9	Laser on/off	switching input Laser on/off	red-blue
10	Zero	switching input Zero	white-green
8	switching output 1	error exit or limit value output	grey-pink
7	switching output 2	limit value output	violett
3	Sync + ¹	symmetrical synchronous-output (Master) or input (Slave)	blue
4	Sync - ¹		pink
1	Tx +	RS422 - output (symmetric)	green
2	Tx -		brown
12	Rx +	RS422 - input (symmetric)	grey
11	Rx -		yellow

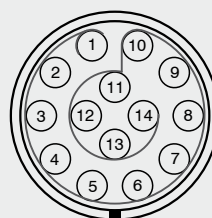

High performance sensors made by Micro-Epsilon



Sensors and systems for displacement, position and dimension

Eddy current sensors
Optical and laser sensors
Capacitive sensors
Inductive sensors
Draw-wire sensors
Optical micrometers
2D/3D profile sensors
Image processing



Sensors and measurement devices for non-contact temperature sensors

Online instruments
Handheld devices



Measuring systems for quality control

for plastic and film
for tire and rubber
for web material
for automotive components
for glass